

CADET™ G2 180-30



2600
PSI

30
L/PM

ELECTRIC MOTOR
11KW 3 PHASE
ENGINE TYPE

POWERLINK
COUPLING
1450RPM
DRIVE

COLD
WATER
OUTPUT



HERO INNOVATIONS

- PEXO™**
Stainless Steel Exoskeleton
- JWPP™**
Jetwave Italian Premium Pump
- DTS™**
Delayed Timer Stop
- BCT™**
Bypass Cooling/Water Buffer Tank
- PL™**
Powerlink Coupling to pump

APPLICATIONS

- Agriculturist**
- Food & Beverage Cleaning**
- Transportation & Logistics**
- Factory Cleaning**

One Product 4 Solutions



STANDOUT FEATURES

- JW® Enhanced** Italian triplex plunger pump running at **1450RPM** delivers more performance and longer life.
- JW® Low speed Italian made**, electric motor, air cooled and protected with thermal cut-out.
- Jetwave Safety System™ (JSS)** safety valve to prevent over pressurisation.
- Seamless & sealed **12L on-board bypass water cooling tank** for added pump protection.
- Quality assured **low 24v** electrical control box & **emergency stop** or increased safety.
- DTS™ Delayed Timer Stop** electronic control for overall unit protection.

STANDARD EQUIPMENT



- Gun:** J5500K LTF Spray Gun
- Lance:** JW Single Lance with JetBlade nozzle socket
- Nozzle:** 1 x JetBlade nozzle & JetBlade nozzle holder
- Hose:** 10m DWB 3/8" Hose with m22 couplings
- Storage:** G2 Washcase

DIMENSIONS

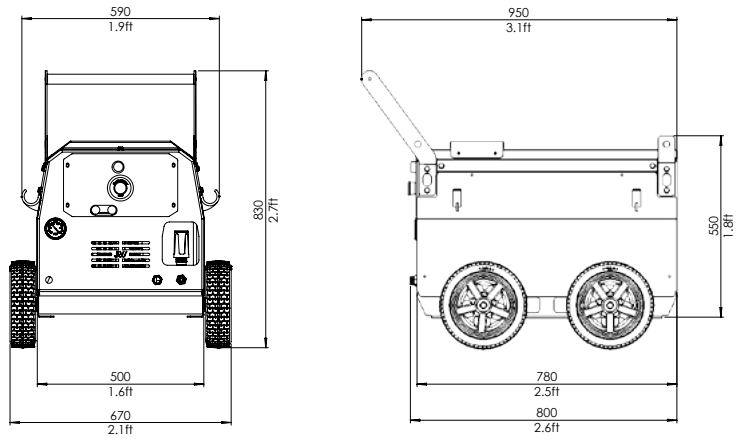

TECHNICAL DATA

CADET™ G2 180-30

Product Code	CW2600-16ELG2
Pressure / Flow Rate	2600 PSI (180 BAR) / 30 L/PM (1800 L/PH) / 8 GPM
Max Water Inlet Temp	50°C / 122°F
Class (ASNSZ: 4223)	Class A (5,400 Bar/Litres)
Usage Frequency	Industrial: Continuous
Nozzle Size	09
Frame Structure	CNC Modular galvanised steel chassis plus satin powder coat finish and stainless steel cover

MOTOR FEATURES

Motor / Power	Induction / 11kW / 3 Phase / 415v / 50Hz / 32A
Cable Length / Control	8M / Delayed Timer Stop DTS™



HYDRAULIC FEATURES

Pump / Head / Pistons	JW® Italian Triplex Plunger / Brass / Ceramic
Motor Pump Coupling / Pump RPM	PowerLink Coupling / 1450RPM
Unloader Valve	Independent - Adjustable
Safety Valve	Yes

DIMENSIONS & WEIGHT

Machine Dimensions / Weight	Skid: 800mm(L) x 665mm(W) x 500mm(H) / 140KG (approx.)
-----------------------------	--

WARRANTY(S)

Unit / Pump Warranty*	 2 Years
Motor Warranty*	 2 Years

OPTIONAL UPGRADES	SKU	OPTIONAL ACCESSORIES	SKU
JW® PRO RAPID 30M HOSE REEL FITTED WITH 30M HOSE	1060CMPL-CG230M	JW® PRO TURBO HEAD	JWA303-09
JW® PRO RAPID 60M HOSE REEL FITTED WITH 60M HOSE	1067CMPL-CG260M	JW® EASY FOAM BOTTLE KIT 1L	JWA731
JW® HOSE REEL ROLLER GUIDE (1067 ONLY)	1067-GUIDE-ASSY	JW® SINGLE BYPASS PRO FOAM COMPLETE KIT	PROFOAM-2.1
JW® CADET G2 WALL MOUNT	90051G2-WALL	JW® DUAL BYPASS PRO FOAM COMPLETE KIT	PROFOAM2-2.1
JW® CADET G2 FLOOR MOUNT	90051G2-STAND	JW® TWIN LANCE (WITH PRESSURE CONTROL)	JW54.2