

# PMG™ G2 VANGUARD 300



**4400**  
PSI

**33**  
L/PM

**V-TWIN PETROL EFI**  
**33HP / 896 CC**  
ENGINE TYPE  
VANGUARD

**GEARBOX**  
1550RPM  
DRIVE

**COLD**  
**WATER**  
OUTPUT



PHOTOS FOR ILLUSTRATION PURPOSES ONLY

## HERO INNOVATIONS



**JWPP™**  
Jetwave Italian Premium Pump



**AVPS™**  
Anti Vibration Protection System



**PMC™**  
Panel/Bulk Head Mounted HP/LP Points



**TURN KEY SOLUTION**  
Quality assured and ready to go

## APPLICATIONS

- High Pressure Cleaning
- Drain Cleaning
- Truck, Ute & Trailer Mounting
- External Water Tank & Bypass Ready

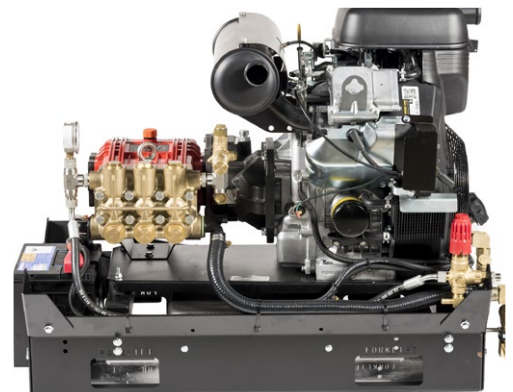
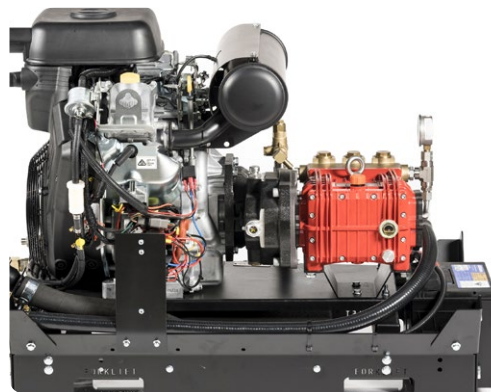

## STANDOUT FEATURES

- JW® Enhanced Italian triplex plunger pump running at 1550RPM delivers more performance and longer life.
- Electric start Industrial V-Twin Vanguard™ Big Block EFI 33HP Series Engine with electronic fuel injection.
- Jetwave Safety System™ (JSS) safety valve to prevent over pressurisation.
- Seamless 25L on-board fuel tank under chassis mount, with level gauge.
- Heavy duty Battery with loom & isolator.
- Integrated forklift pockets & mounting points.

## MOUNTING FOOTPRINT

## DIMENSIONS (MM)

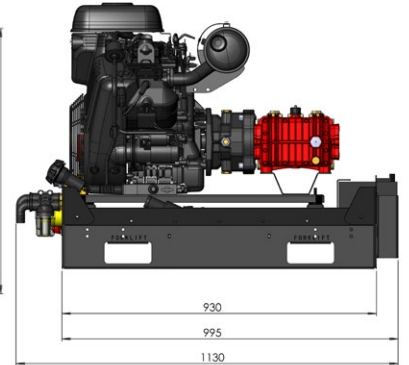
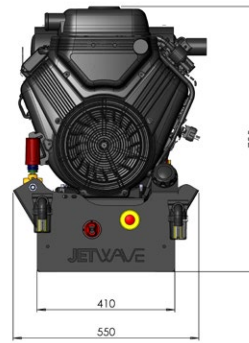
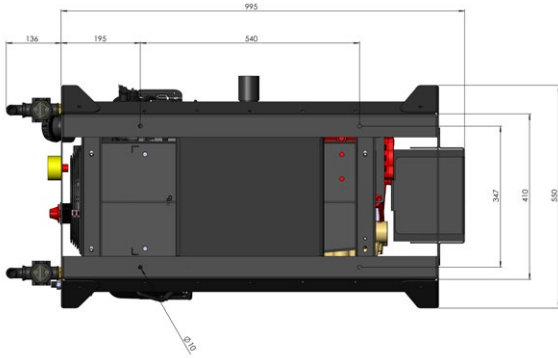

## TECHNICAL DATA

## PMG G2 VANGUARD 300

Product Code	PM4000-33PEG2
Pressure / Flow Rate	4440 PSI (300 BAR) / 33 L/PM
Max Water Inlet Temp	60C°
Class (ASNZS: 4223)	B (9,900 Bar/Litres)
Usage Frequency	Professional: 4 Hours Daily
Nozzle Size	08
Frame Structure	CNC Modular galvanised steel chassis plus satin powder coat finish

## MOTOR FEATURES

Engine / Power	Vanguard™ EFI Big Block (B&S) Electric Start (air cooled) 33HP / 896cc
Fuel Type / Capacity	Unleaded / 25L (w/level gauge)

## HYDRAULIC FEATURES

Pump / Head / Pistons	JW® Italian Triplex Plunger / Brass (Nickle Plated) / Ceramic
Motor Pump Coupling / Pump RPM	Gearbox Drive / 1550RPM
Unloader Valve	Independent
Safety Valve	Yes

## DIMENSIONS & WEIGHT

Machine Dimensions / Weight	1130mm(L) x 550mm(W) x 785mm(H) / 150KG (approx.)
-----------------------------	---

## WARRANTY(S)

Pump Warranty*	 2 Years
Engine Warranty*	 3 Years

## OPTIONAL ACCESSORIES

## OPTIONAL UPGRADES

21" Hammerhead - Stainless Steel	JWA-FSC21-5.08
30" Hammerhead - Stainless Steel	JWA-FSC30.08

Copyright © 2023 Jetwave® Group Pty Ltd. All Rights Reserved.

The manufacturer reserves the right to modify design features and technical facts without notice, due to our principals of continuous improvement.

\*Coverage against defects in material and workmanship (refer to Jetwave's and component partners T&Cs).

V3.0 02/23