

HORNET™ G2 iGX 200-21



3000
200 BAR
PSI

21
L/PM

HONDA iGX390
PETROL
ENGINE TYPE
POWERED BY HONDA

GEARBOX
1450RPM
DRIVE

COLD
WATER
OUTPUT



HERO INNOVATIONS



PEXO™
Stainless Steel Exoskeleton



JWPP™
Jetwave Italian Premium Pump



CC™
Centralised Control



AVPS™
Anti Vibration Protection System



AST™
Auto Speed Technology



UDOR
WATER POWER
Registered Design © 202215870

APPLICATIONS



Tradesmen



Commercial Cleaners



Agriculturist



Construction



STANDOUT FEATURES



JW® UDOR® Premium Italian plunger pump running at 1450RPM, delivers more performance and longer life.



Intelligent Honda™ iGX390 Industrial Series Engine with automatic RPM's & choke sensor with electric key start (back up pull start).



Jetwave Safety System™ (JSS) thermal and safety valve to prevent overheating in excessive bypass and over pressurisation.



Zero line pressure brass adjustable unloader valve.



Battery isolator to prevent battery voltage loss, when not in use.



Emergency stop for increased operator safety.

STANDARD EQUIPMENT



Gun: J5500k low trigger force gun w/swivel & lance coupling system.

Lance: JW Straight stainless steel lance w/ snap coupling + nozzle w/protector & tail



Hose: 15m non marking double wire braid hose w/M22 couplings



Chemical: JW easy foam kit w/1L bottle



G2 WASHBOX VIDEO

DIMENSIONS (MM)

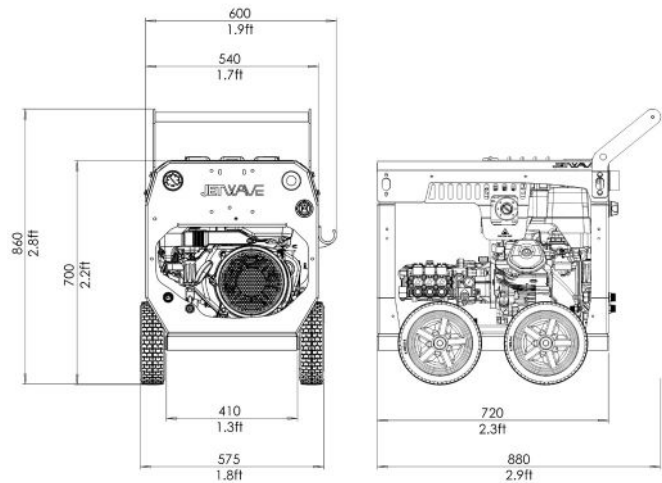

TECHNICAL DATA 0:00

HORNET® G2 iGX 200-21

Product Code	CW3000-21PEIG2
Pressure / Flow Rate	3000 PSI (200 BAR) / 21 L/PM (1260 L/PH) / 5.5 GPM
Max Inlet Temp	60°C/ 140°F
Class (AS/NZS: 4223)	A (4.200 Bar/Litres)
Usage Frequency	Professional: Daily
Nozzle Size	06
Frame Structure	CNC Modular skid galvanised steel chassis plus satin powder coat finish and stainless steel cover

MOTOR FEATURES

Engine / Power	Honda™ iGX390 Electric Start (air cooled w/auto speed tech) 13HP / 390cc
Fuel Type / Capacity / Protection	Unleaded / 6.1L / Low Oil Shutdown

HYDRAULIC FEATURES

Pump / Head / Pistons	JW® UDOR® Premium Triplex Plunger / Brass (Nickle Plated) / Ceramic
Motor Pump Coupling / Pump RPM	Gearbox Drive / 1450RPM
Unloader Valve	Independent (Zero) - Adjustable (Panel Mounted)
Safety Valve	Yes

DIMENSIONS & WEIGHT

Machine Dimensions / Weight	880mm(L) x 575mm(W) x 860mm(H) / 90KG (approx.)
-----------------------------	---

WARRANTY(S)

Unit / Pump Warranty*	 2 Years
Engine Warranty*	 3 Years

OPTIONAL ACCESSORIES

30m Hose Reel	1060CMPL-H30M
JW Pro Turbo Head	JWA303-06
21" Hammerhead FSC - Stainless Steel	JWA-FSC22-5.06

OPTIONAL UPGRADES

Wheel Brake System Kit	JWA-WBS
Engine Hour Meter	TACHHOUR8075

Copyright © 2023 Jetwave® Group Pty Ltd. All Rights Reserved.

The manufacturer reserves the right to modify design features and technical facts without notice, due to our principals of continuous improvement.

*Coverage against defects in material and workmanship (refer to Jetwave's and component partners T&Cs).

V3.0 08/23