



# JETWAVE®

## HIGH PRESSURE CLEANERS

# EXPLORER™ G2 TRAILER



Trailer



Petrol or Diesel



Hot Water



Daily Usage

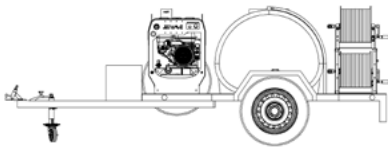

POWERED by **HONDA™**

**KOHLER.** Diesel

## MODELS

### EXPLORER G2

PETROL [FIND OUT MORE](#)  
4060 PSI • 15 L/PM

### EXPLORER G2D

DIESEL [FIND OUT MORE](#)  
3150 PSI • 15 L/PM

DIESEL [FIND OUT MORE](#)  
4060 PSI • 13 L/PM



READ MORE ABOUT THE EXPLORER G2  
**FAMILY BOOKLET**



The Jetwave® Explorer G2 & Explorer G2D Trailer is designed and built to Australian conditions from the best quality components. A turn key solution for portable pressure washing, featuring the next generation of innovative pressure cleaners boasting the best technology for safety and performance.

## STANDOUT FEATURES



Quick release tow coupling with 50mm ball.



Heavy duty washable water inlet filter.



Heavy duty jockey wheel.



Mechanical override braking system.



Full galvanised construction.



Multi voltage 12/24v LED lights recessed to protect.



Sunraysia style wheels.



Bypass back into tank.



Heavy duty tyres.



Low level water cut out protection.



Polyethylene 1000L water tank and top fill.



High flow float valve auto shut off, for water inlet.



Spare wheel.



Heavy duty hose reels.



Trailer lead-7 pin male plug.

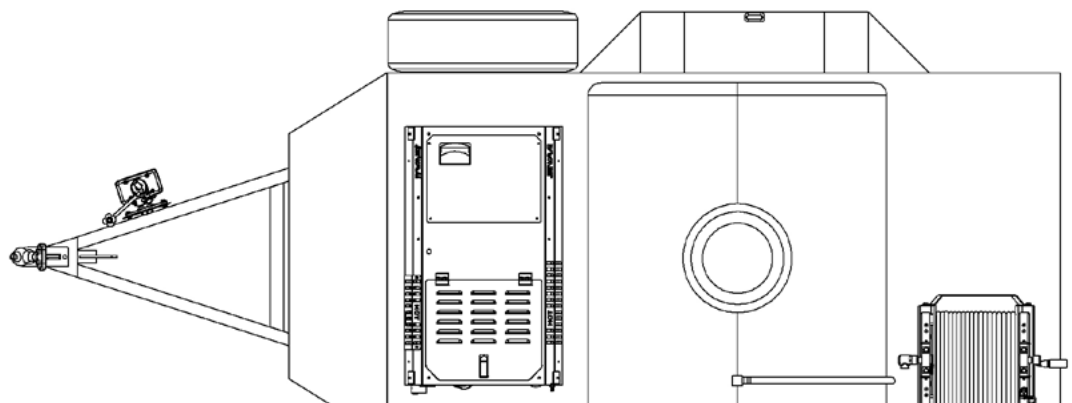

# EXPLORER™ G2

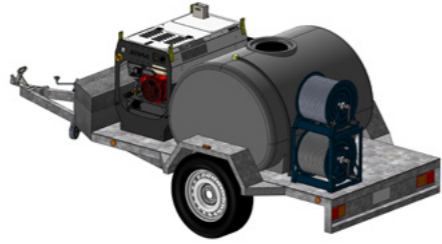

# EXPLORER™ G2D

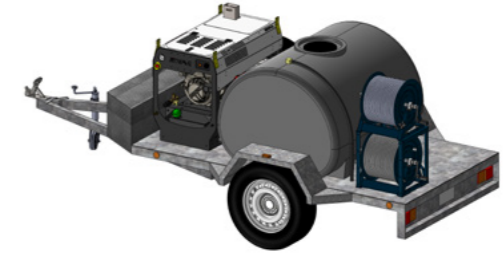

## Explorer G2 & G2D

- Stainless Steel Exoskeleton (PEXO™)
  - Centralised control
  - Emergency stop
- JW® Italian premium pump

Water by-pass return to tank for unit cooling

Spare wheel

Inspection port with connected lid

1000L UV stabilised Water cartage tank

High flow inlet float valve auto shutoff

Welded RHS/DuraGal® frame & Bracing

2mm unique galvanised sheet Full trailer base

Recessed led taillights

Low pressure inlet hose reel fitted with 30m of 3/4" hose

High pressure outlet hose reel fitted with 30m of double wire braid 400 bar rated hose

Optional: Aluminium tool box

Heavy duty jockey wheel

Hydraulic brake system with Manual hand brake

Extra length "a-frame" draw bar for smooth towing

Led side clearance lights

Heavy duty water filter

Light truck tyres

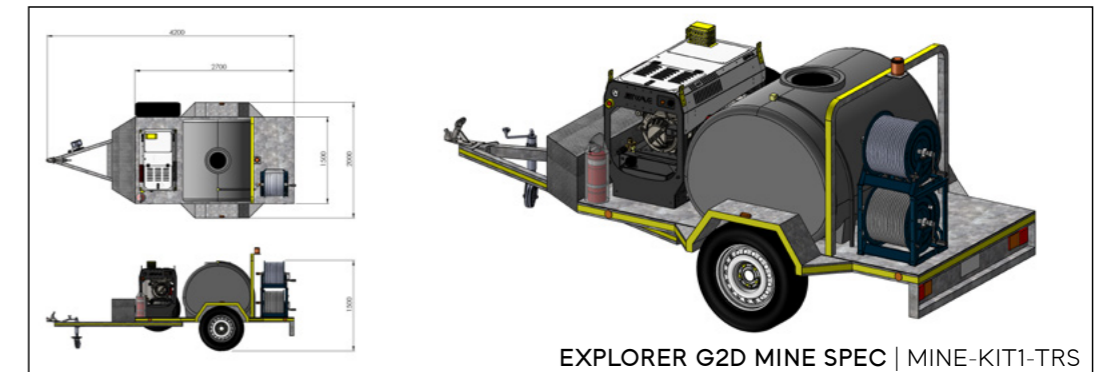
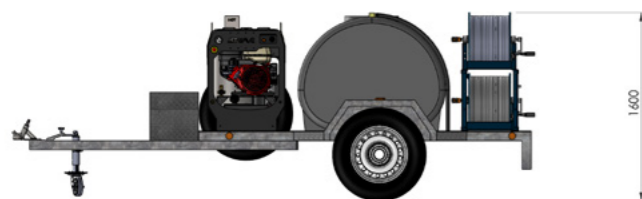
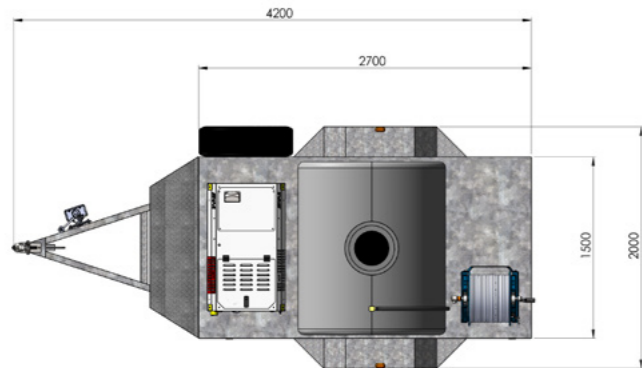

EXPLORER G2D MINE SPEC | MINE-KIT1-TRS



**Apache Hose Reels** - 100m capacity of 3/8" Steel construction with double ball bearing support & welded hub. Double stack kit 30m 3/8" DWB high pressure hose & 30m 3/4" low pressure inlet hose.

**Water Tank** - 1000L for water cartage

**Spare Wheel** - For safety & convenience on site

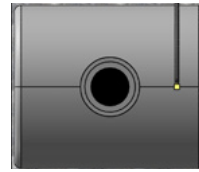

Jetwave Group  
 10-16 Smith Street Thebarton I  
 Adelaide I South Australia I 5031 I AU  
 +61 8 8371 3599  
 sales@jetwave.com.au  
 jetwave.com.au

**STANDARD EQUIPMENT**

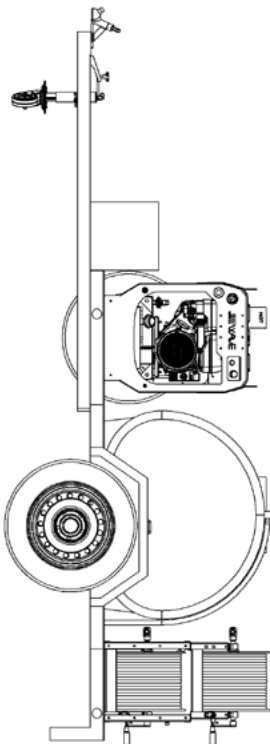

<b>TANK CAPACITY</b>		1000L
Product Code	p/n	TRS-KIT7
<b>TRAILER FEATURES</b>		
Origin	country	Made in Australia
Axle	no.	1
Wheels	type	6 Stud Sunraysia Light Truck
Axle Thickness	type	50mm With Parallel Bearings
Braking System	type	Hydraulic 10" Drum with Override
Light Voltage	type	Multi Voltage 12/24v LED
Spare Wheel	y / n	Y
Material Finish	type	Galvanised
Trailer Rating	weight	1875kg
Tow Hitch	type	50mm Ball Coupling
Jockey Wheel	type	AL-KO or equivalent
Suspension System	type	9 Leaf HD
<b>WATER TANK FEATURES</b>		
Origin	country	Australian
Level Gauge	y / n	Y
Tank Fill Lid	type	Connected (Quarter Turn)
UV Stabilised	y / n	Y
<b>DIMENSIONS &amp; WEIGHT</b>		
Approx Weight	kg	800 (dry) / 1800 (wet)
Unit Dimensions	mm	4200(L) x 2000(W) x 1600(H)
<b>WARRANTY(S)</b>		
Trailer Warranty	year	1
Water Cartage Tank Warranty	years	15

1500mm Draw Bar Mounted Alloy Tool Box

Hose Reel Guides

Roll bar + night working lights & beacon

Mine Spec Kit (Diesel Only)

Jerry Can Holder (each) Petrol - Red I Diesel - Yellow

JW Pro Foam Bypass System



31601



2100463



JWA425



MINE-KIT1-TRS



JWA427



PROFOAM

**OPTIONAL EQUIPMENT**

