

# EXECUTIVE™ G2 350-23



**5075**  
350 BAR  
**PSI**

**23**  
**L/PM**

**HONDA GX690**  
**PETROL**  
**ENGINE TYPE**  
POWERED by HONDA

**GEARBOX**  
**1450RPM**  
**DRIVE**

**HOT**  
**WATER**  
**OUTPUT**



## HERO INNOVATIONS

- ETL™**  
Engineered Top Lifting Lugs
- PEXO™**  
Stainless Steel Exoskeleton
- JWPP™**  
Jetwave UDOR™ Italian Premium Pump
- CC™**  
Centralised Control
- AVPS™**  
Anti Vibration Protection System



## APPLICATIONS

- Tradesmen
- Commercial Cleaners
- Shipping & Logistics
- Construction/Earth Moving

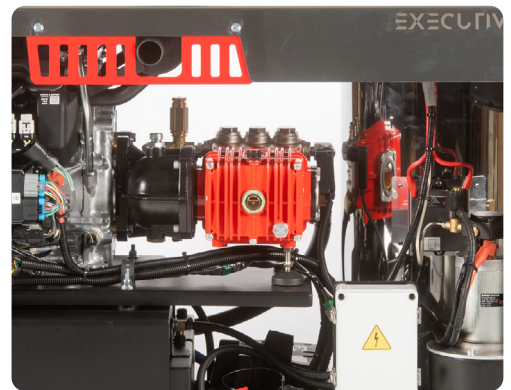

## STANDOUT FEATURES

- JW® UDOR® Premium Italian plunger pump running at 1450RPM, delivers more performance and longer life.
- Electric start Industrial V-Twin Honda™ GX690 Series Engine with digital engine hour meter.
- Jetwave Safety System™ (JSS) thermal and safety valve to prevent overheating in excessive bypass and over pressurisation.
- Vertical burner with GeniSys™ 12v Advanced Burner Control with smart sensors and protective features.
- Battery isolator & Emergency stop for increased safety and longevity.
- Seamless under chassis mounted dual fuel tanks protected from heat with front fill point safety.

## STANDARD EQUIPMENT



**Gun:** J5500k low trigger force gun w/swivel & lance coupling system.

**Lance:** JW Straight stainless steel lance w/ snap coupling + nozzle w/protector & tail



**Hose:** 15m non marking double wire braid hose w/M22 couplings

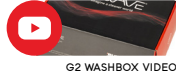

G2 WASHBOX VIDEO

## DIMENSIONS (MM)

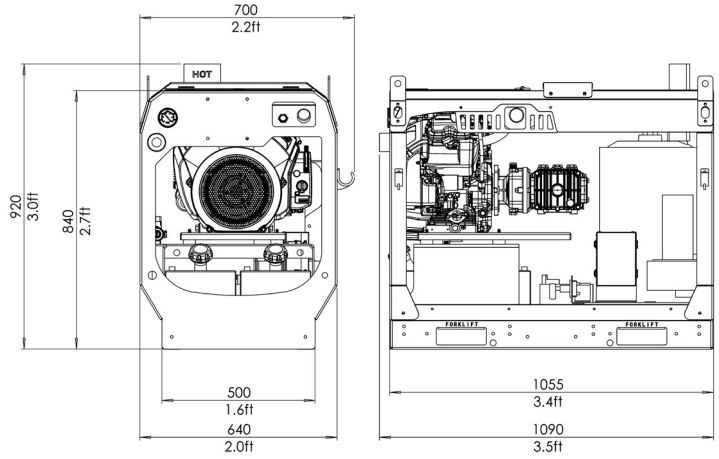

## TECHNICAL DATA

## EXECUTIVE™ G2 350-23

Product Code	HW5000-23PG2
Pressure / Flow Rate	5075 (350 BAR) / 23 L/PM (1380 L/PH) / 6 GPM
Max Water Inlet / Outlet Temp	60°C / 90°C
Class (ASNZS: 4223)	A (8,050 Bar/Litres)
Usage Frequency	Professional: Daily Usage
Nozzle Size	05
Frame Structure	CNC Modular skid galvanised steel chassis plus satin powder coat finish and <b>stainless steel cover</b>

## MOTOR FEATURES

Engine / Power	Honda™ GX690 Electric Key Start (air cooled) 23 HP / 690 CC
Fuel Type / Capacity / Protection	Unleaded / 17L / Low Oil Shutdown

## HYDRAULIC FEATURES

Pump / Head / Pistons	JW® UDOR® Premium Triplex Plunger / Brass (Nickle Plated) / Ceramic
Motor Pump Coupling / Pump RPM	Gearbox Drive / 1450RPM
Unloader Valve	Independent - Adjustable
Safety Valve	Yes
Detergent Injector	No



## THERMAL FEATURES

Burner Model	Vertical 12v V Series
Fuel Supply / Capacity / Consumption	Diesel / 17L / 5.74 L/PH
Coil / Housing Material	Mild steel 3mm wall <b>seamless</b> (400BAR rated) / Stainless Steel

## DIMENSIONS & WEIGHT

Machine Dimensions / Weight	Skid: 1090mm(L) x 700mm(W) x 920mm(H) / 295KG (approx.)
-----------------------------	---

## WARRANTY(S)

Unit / Pump Warranty*	 2 Years
Engine Warranty*	 3 Years

## OPTIONAL ACCESSORIES

## OPTIONAL UPGRADES

30m Hose Reel w/30m hose	1060Cmpl-EX30M	4 Wheel Trolley Kit A (4 x Off road wheels)	JWA407
60m Hose Reel w/60m hose	1067Cmpl-EX60M	4 Wheel Trolley Kit B (2 x Off road wheels + 2 x caster wheels)	JWA407E
JW Pro Turbo Head	JWA160.05	Hose Reel Roller Guide HGS™	1067-GUIDEASSY (1067 Only)
21" Hammerhead - ABS Plastic	JWA-FSC21		
21" Hammerhead - Stainless Steel	JWA-FSC21-5		

Copyright © 2023 Jetwave® Group Pty Ltd. All Rights Reserved.

The manufacturer reserves the right to modify design features and technical facts without notice, due to our principals of continuous improvement.

\*Coverage against defects in material and workmanship (refer to Jetwave's and component partners T&Cs).

V3.0 08/23