



# SCORPION™ G2 TRAILER



Trailer



Petrol Driven



Cold Water



Daily Usage

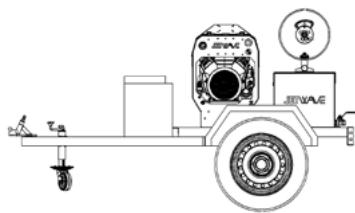

The Jetwave® Scorpion G2 Trailer is designed and built to Australian conditions from the best quality components. A turn key purpose built solution for portable plumbing fleet water jetting, featuring the next generation of innovative water jetters boasting the best technology, safety and performance.



POWERED BY **HONDA**™

## MODELS

### SCORPION™ G2

4000 PSI • 20 L/PM [FIND OUT MORE](#)

4350 PSI • 26 L/PM [FIND OUT MORE](#)

5000 PSI • 16 L/PM [FIND OUT MORE](#)

5075 PSI • 23 L/PM [FIND OUT MORE](#)

### SCORPION™ G2FI

4350 PSI • 31 L/PM [FIND OUT MORE](#)

5075 PSI • 25 L/PM [FIND OUT MORE](#)



READ MORE ABOUT THE SCORPION G2 FAMILY BOOKLET



## STANDOUT FEATURES



Quick release tow coupling with 50mm ball.



Heavy duty jockey wheel.



Full galvanised construction.



Sunraysia style wheels.



Heavy duty tyres.



Polyethylene 200L water tank and top fill.



Trailer lead-7 pin male plug.



Heavy duty washable water inlet filter.



Multi voltage 12/24v LED lights recessed to protect.



Bypass back into tank.



Low level water cut out protection.



High flow float valve auto shut off, for water inlet.



Professional high & low pressure duty hose reels

- 30m for low pressure inlet water feed
- 60m for high pressure primary hose water outlet

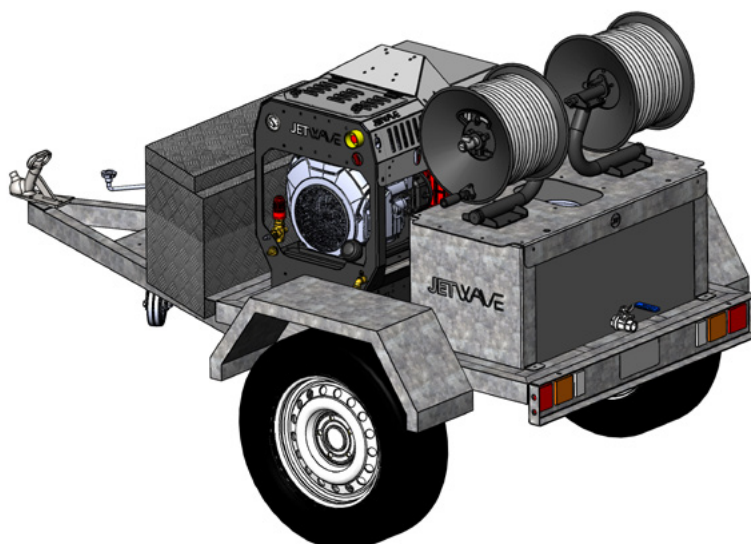

**SCORPION™ G2**



**SCORPION™ G2FI**



**Scorpion G2 & G2FI**

- Stainless Steel Exoskeleton (PEXO™)
  - Centralised control
    - Battery isolator
    - Emergency stop
- JW® Italian premium pump

Optional: Aluminium storage box

Optional: Remote mini reel

Heavy duty jockey wheel

Easy fuel fill

Extra length "a-frame" draw bar for smooth towing

Led side clearance lights

Ranger style light truck tyres

Water by-pass return to tank for unit cooling

Ball valve for on/off pressure control

High pressure outlet hose reel fitted with 60m of water jetting hose

Inspection port with connected lid

200L UV stabilised Water cartage tank

Welded RHS/DuraGal® frame & Bracing

Recessed led taillights

2mm unique galvanised sheet Full trailer base

Oversized water tank drain outlet

High flow inlet float valve auto shutoff

Low pressure inlet hose reel fitted with 30m of 3/4" hose

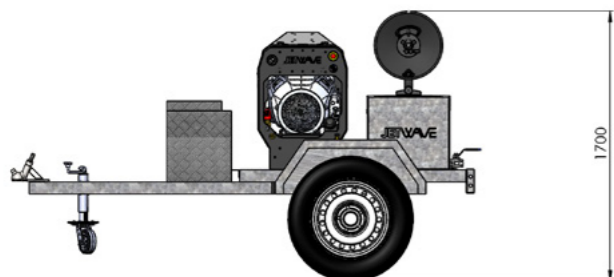
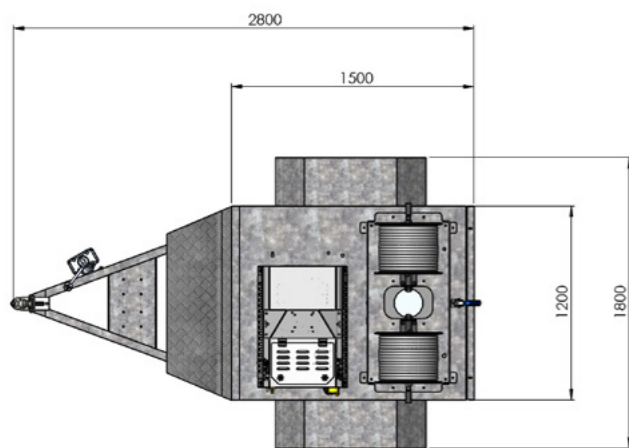



Jetwave Group  
 10-16 Smith Street Thebarton I  
 Adelaide I South Australia I 5031 I AU  
 +61 8 8371 3599  
 sales@jetwave.com.au  
 jetwave.com.au

2x Pro Rapid Style Hose Reels - 60m 3/8"  
 Water jetting high pressure hose & 30m 3/4"  
 low pressure inlet hose.



Water Tank - 200L for  
 water cartage

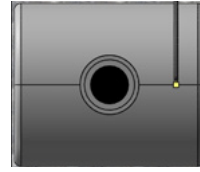

Remote Reel Locking Plate  
 - Locking plate for to secure  
 remote reel



STANDARD EQUIPMENT

Product Code	p/n	TRS-KIT1
<b>TRAILER FEATURES</b>		
Origin	country	Made in Australia
Axle	no.	1
Wheels	type	6 Stud Sunraysia Light Truck
Axle Thickness	type	45mm With HD Bearings
Light Voltage	type	Multi Voltage 12/24v LED
Spare Wheel	y / n	N
Material Finish	type	Galvanised
Trailer Rating	weight	750kg
Tow Hitch	type	50mm Ball Coupling
Jockey Wheel	type	AL-KO or equivalent
Suspension System	type	5 Leaf Slipper
<b>WATER TANK FEATURES</b>		
Origin	country	Australian
Tank Fill Lid	type	Connected
UV Stabilised	y / n	Y
Tank Capacity	litres	200
<b>DIMENSIONS &amp; WEIGHT</b>		
Approx Weight	kg	450 (dry) / 650 (wet)
Unit Dimensions	mm	2700(L) x 1800(W) x 1600(H)
<b>WARRANTY(S)</b>		
Trailer Warranty	year	1
Water Cartage Tank Warranty	years	15

1200mm Draw Bar  
 Mounted Alloy Tool Box



31601

Jerry Can Holder (each)  
 Petrol - Red



JWA427

Remote Mini Reel



PW134-RRCMPL/HOP4

Apache A-Frame Hose  
 Reels Upgrade



JWA120

Hose Reel Guides



2100463

OPTIONAL EQUIPMENT

