

EXPLORER™ G2 280-15



3650
250 BAR
PSI

15
L/PM

HONDA iGX390
PETROL
ENGINE TYPE
POWERED BY HONDA.

GEARBOX
1450RPM
DRIVE

HOT WATER
OUTPUT

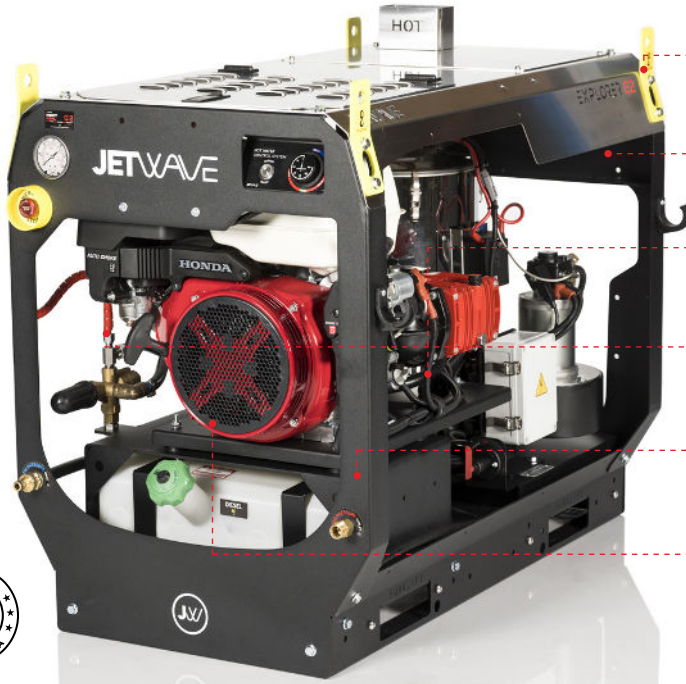

HERO INNOVATIONS

- TLL™**
Top Lifting Lugs
- PEXO™**
Stainless Steel Exoskeleton
- JWPP™**
Jetwave Italian Premium Pump
- CC™**
Centralised Control
- AVPS™**
Anti Vibration Protection System
- AST™**
Auto Speed Technology

LEARN MORE Explorer G2 Video



Registered Design © 202215869

APPLICATIONS

- Tradesmen
- Commercial Cleaners
- Agriculturist
- Construction/Earth Moving

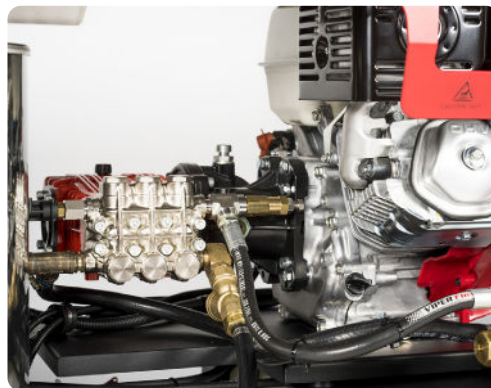

STANDOUT FEATURES

- JW® UDOR® Premium Italian plunger pump running at 1450RPM, delivers more performance and longer life.
- Intelligent Honda™ iGX390 Industrial Series Engine with automatic RPM's & choke sensor with electric key start (back up pull start).
- Jetwave Safety System™ (JSS) thermal and safety valve to prevent overheating in excessive bypass and over pressurisation.
- Zero line pressure brass adjustable unloader valve.
- Vertical burner with GeniSys™ 12v Advanced Burner Control with smart sensors and protective features.
- Battery isolator & Emergency stop for increased safety and longevity.

STANDARD EQUIPMENT



Gun: J5500k low trigger force gun w/swivel & lance coupling system.

Lance: JW Straight stainless steel lance w/ snap coupling + nozzle w/protector & tail



Hose: 15m non marking double wire braid hose w/M22 couplings



Chemical: JW easy foam kit w/1L bottle



G2 WASHBOX VIDEO

DIMENSIONS (MM)

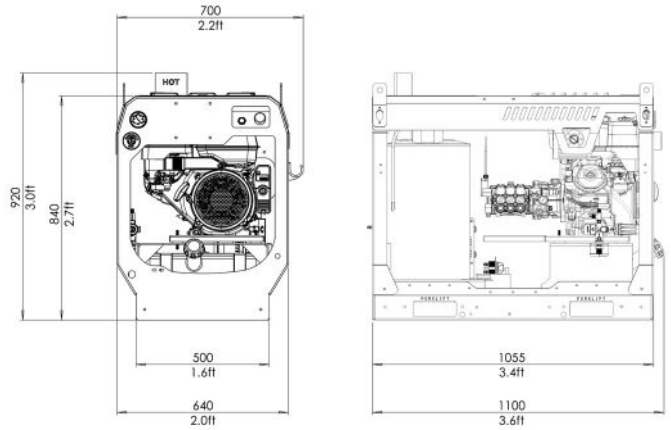

TECHNICAL DATA 0:00

EXPLORER G2 280-15

Product Code	HW4000-15PG2
Pressure / Flow Rate	3650 (250 BAR) / 15 L/PM (900 L/PH) / 4 GPM
Max Water Inlet / Outlet Temp	60°C / 90°C
Class (AS/NZS: 4223)	A (3,750 Bar/Litres)
Usage Frequency	Professional: Daily Usage
Nozzle Size	O4
Frame Structure	CNC Modular skid galvanised steel chassis plus satin powder coat finish and stainless steel cover

MOTOR FEATURES

Engine / Power	Honda™ iGX390 Electric Start (air cooled w/auto speed tech) 13HP / 390cc
Fuel Type / Capacity / Protection	Unleaded / 6.1L / Low Oil Shutdown

HYDRAULIC FEATURES

Pump / Head / Pistons	JW® UDOR® Premium Triplex Plunger / Brass (Nickle Plated) / Ceramic
Motor Pump Coupling / Pump RPM	Gearbox Drive / 1450RPM
Unloader Valve	Independent (Zero) - Adjustable
Safety Valve	Yes



THERMAL FEATURES

Burner Model	Vertical 12v V Series
Fuel Supply / Capacity / Consumption	Diesel / 20L / 5.74 L/PH
Coil / Housing Material	Mild steel 3mm wall seamless (400BAR rated) / Stainless Steel

DIMENSIONS & WEIGHT

Machine Dimensions / Weight	Skid: 1100mm(L) x 700mm(W) x 920mm(H) / 280KG (approx.)
-----------------------------	---

WARRANTY(S)

Unit / Pump Warranty*	 2 Years
Engine Warranty*	 3 Years

OPTIONAL ACCESSORIES

OPTIONAL UPGRADES

30m Hose Reel w/30m of hose	1060CMPL-EXP30M	Engine Hour Metre	TACHHOUR8075
60m Hose Reel w/60m of hose	1067CMPL-EXP60M	4 Wheel Trolley Kit A (4xOffroad Wheels)	JWA407
JW Bypass Pro Foam	PROFOAM	4 Wheel Trolley Kit B (2xCastor Wheels 2xOffroad Wheels)	JWA407E
JW Pro Turbo Head	JWA1303.04	Hose Reel Roller Guide HGS™	1067-GUIDEASSY
21" Hammerhead - ABS Plastic	JWA-FSC21		
21" Hammerhead - Stainless Steel	JWA-FSC21-5		

Copyright © 2023 Jetwave® Group Pty Ltd. All Rights Reserved.

The manufacturer reserves the right to modify design features and technical facts without notice, due to our principals of continuous improvement.

*Coverage against defects in material and workmanship (refer to Jetwave's and component partners T&Cs).

V3.0 08/23